

Bodyshell fixing screws

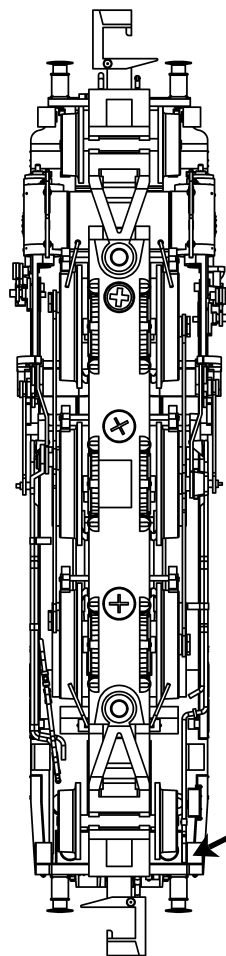

First screw - secures running plate to chassis

Second screw - secures shell of loco to running plate

Screw each side secures bunker to chassis

Thank you for your choice of the Graham Farish BR Standard Class 3 2-6-2T locomotive.

Running in

The mechanism of this model requires running in (without a load) for approximately 1 hour in each direction at moderate speed.

Curves

This locomotive performs best on track with curves of second radius (**approx. 10.5 inches / 260 mm**) or greater. Please check clearances for that front and rear steps before final fitting.

Body removal

The bodyshell is secured by the screws underneath shown on page 4

DCC Decoder fitting to non DCC fitted loco

This model has an 6-pin NMRA/NEM 651 socket in the tender suitable for a decoder with an appropriate plug. Align the decoder as indicated.

Run in as above using a DC power supply before fitting a DCC decoder

Lubrication

When required, sparingly lubricate the motor bearings using plastic compatible light oil and the gear train with model grease. Suitable lubricants are Bachmann E-Z Lube item 99984 or Woodland Scenics 'HobbyLube' Lite Oil item HL654.

Bachmann Europe Plc

Moat Way, Barwell, Leicestershire, LE9 8EY

Tel: 01455 841756

www.bachmann.co.uk

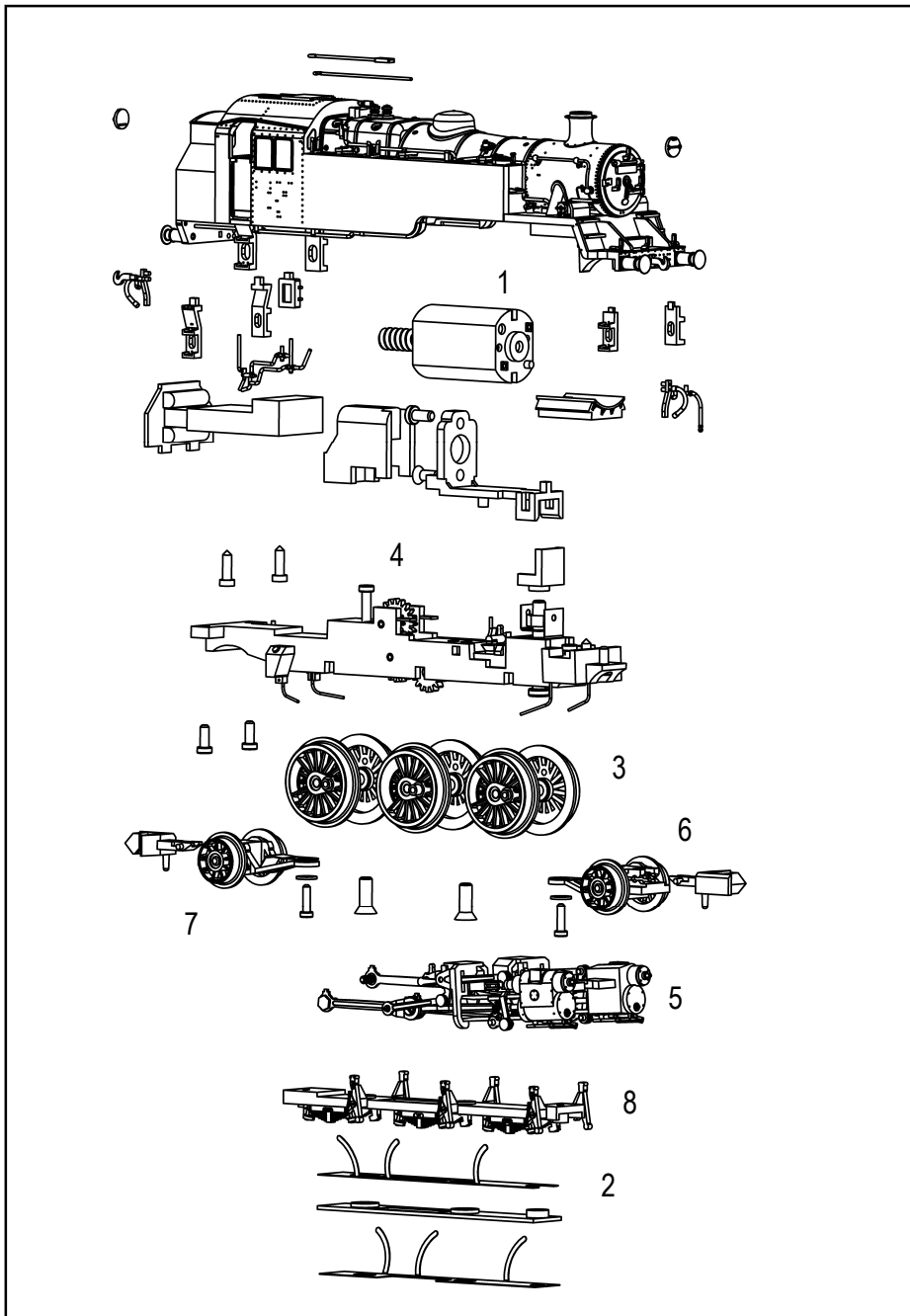

Parts

- 1 Motor
- 2 Pickups
- 3 Driving wheels
- 4 Gears
- 5 Cylinders / motion
- 6 Front pony truck
- 7 Rear pony truck
- 8 Loco baseplate

Add-on detail parts

- Parts fit as shown on the diagram:
- vacuum / steam pipes and cosmetic couplings to bufferbeams
 - steps to front and rear corners
 - tools to tool holder on offside tank top
 - train headcode disc to lampirons on smokebox and bunker

Replacement parts in retail packs

Couplings - item 379-405

Fitting DCC decoder

Remove loco shell only (see page 4)

Carefully remove the blanking board above the motor and replace with a decoder having a NMRA/NEM 651 6-pin fitting -for example Bachmann item 36-558

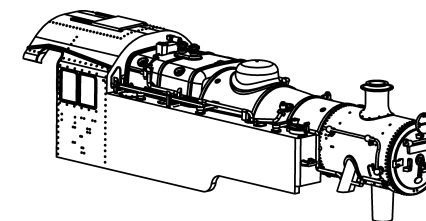

Pin 1

